

Ground plan:
Horizontal section at 6' high
 - solid line: extents below cut plane
 - dashed line: extents above cut plane
 - grey: cutting surface

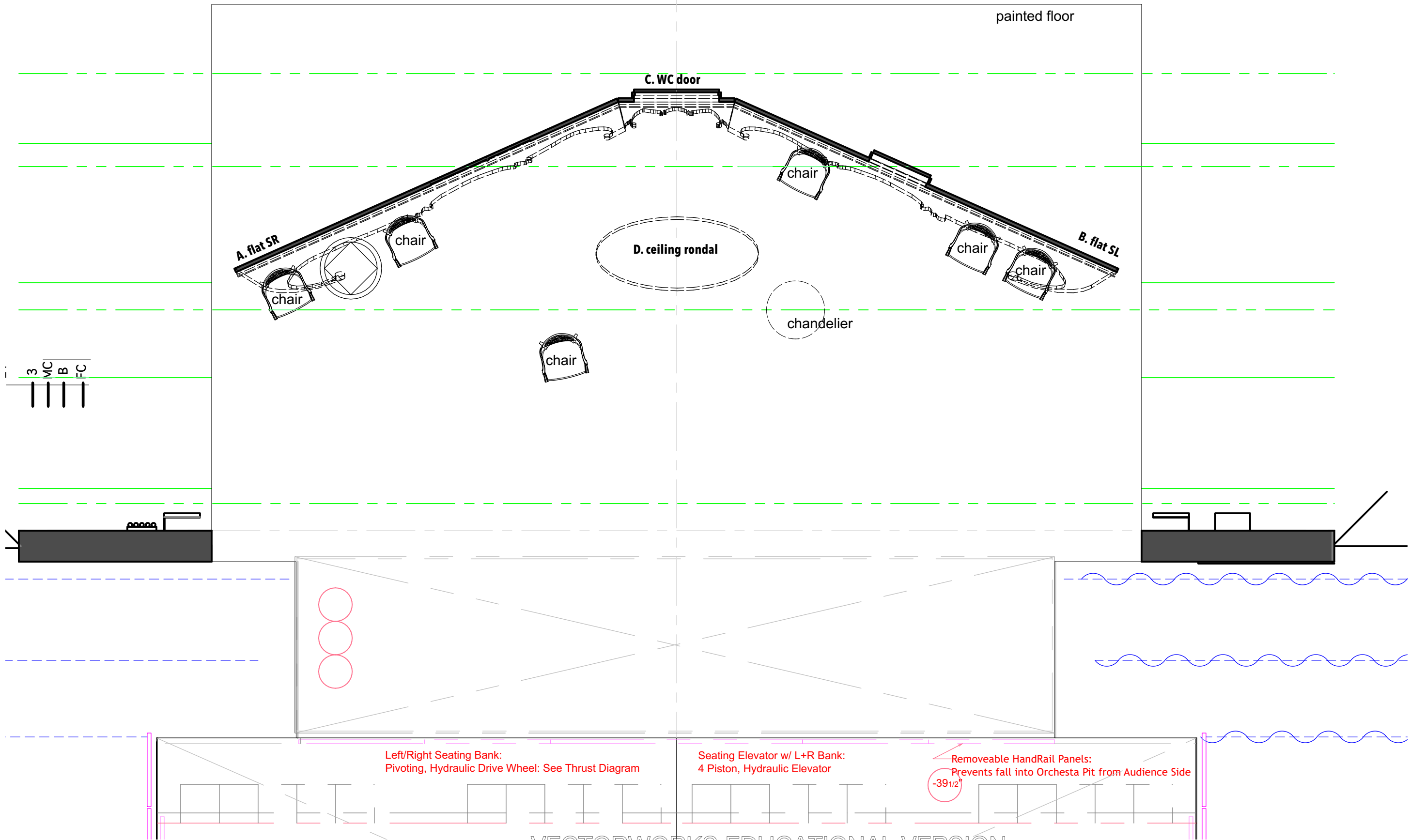

University of New Mexico Theatre and Dance Department		1	Of 4
The Imaginary Invalid		ground plan	Date: Jan 30, 2024
Director: Alejandro Rodriguez Scene Designer: Inseung Park Technical Director: Richar Hess		Drafter: Inseung Park	Scale: 1/4" = 1'-0"

PIN RAIL / CATWALK

PIPE GRID

2

Of 4

Proscenium:
21'-6" H

Hole in
Catwalk

Steel
Ladder

Projection
Bridge

Building
Structure
(Offstage)

Building
Structure
(Offstage)

ceiling rondal

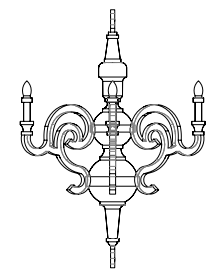

TRAPS AND STEEL I-BEAMS

Stage Level

Musician
Exit
SL Only

SR
Storage

-71 1/2"

Orchestra Level

-123"

Trap Room Level!

Pit Lift

Seating Bank Lift
in Proscenium
(Lowered Configuration)

Rodey Theatre
Section View: Stage Left

University of New Mexico Theatre and Dance Department

The Imaginary Invalid

section

Date: Jan 30, 2024

Scale: 1/4" = 1'-0"

Drafter: Inseung Park

Director: Alejandro Rodriguez
Scene Designer: Inseung Park
Technical Director: Richar Hess

A-1 wall unit SR: front

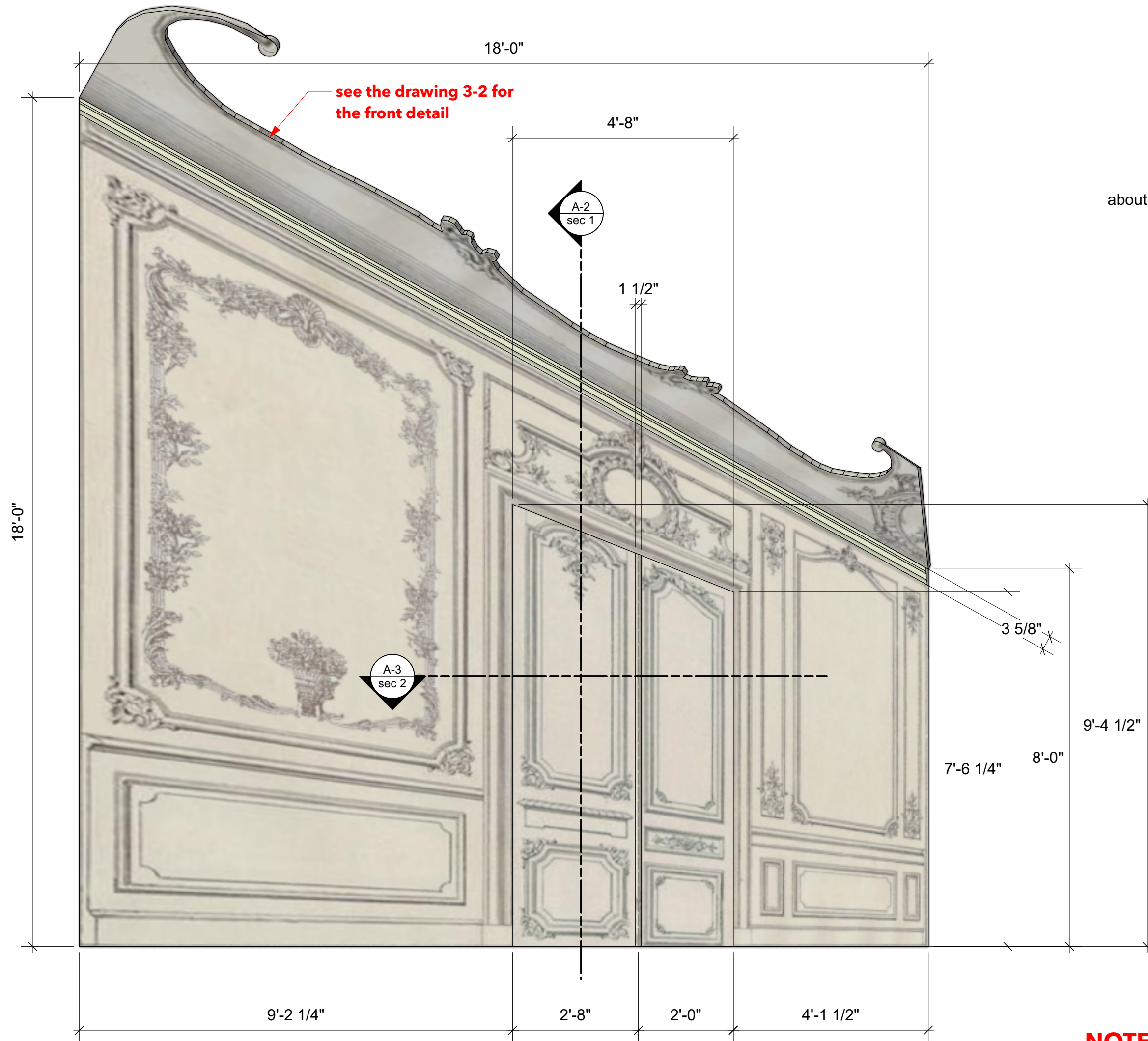

A-2 wall unit SR: section 1
scale: 1"=1'-0"

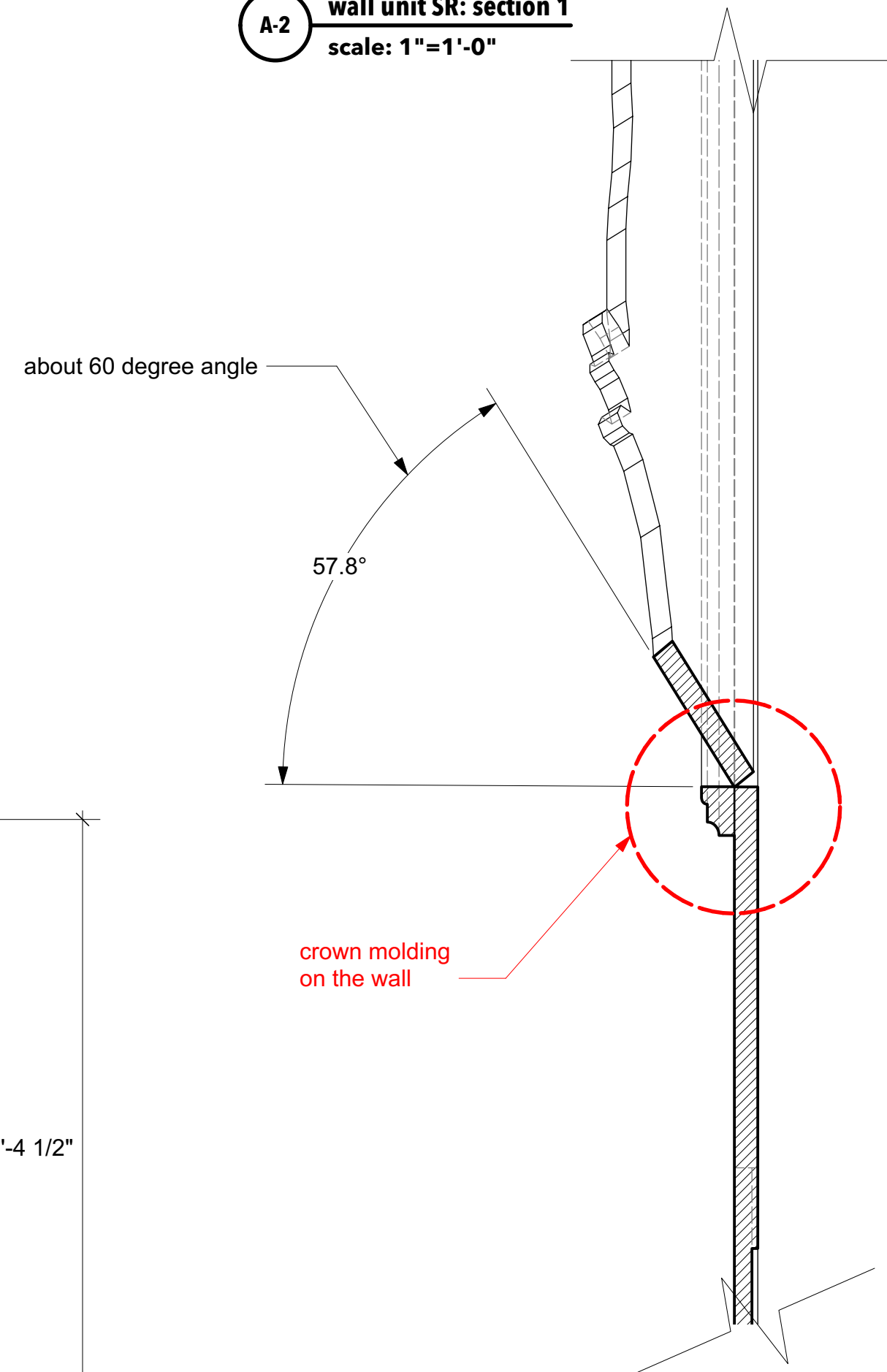

A-3 wall unit SR: section 2
scale: 1"=1'-0"

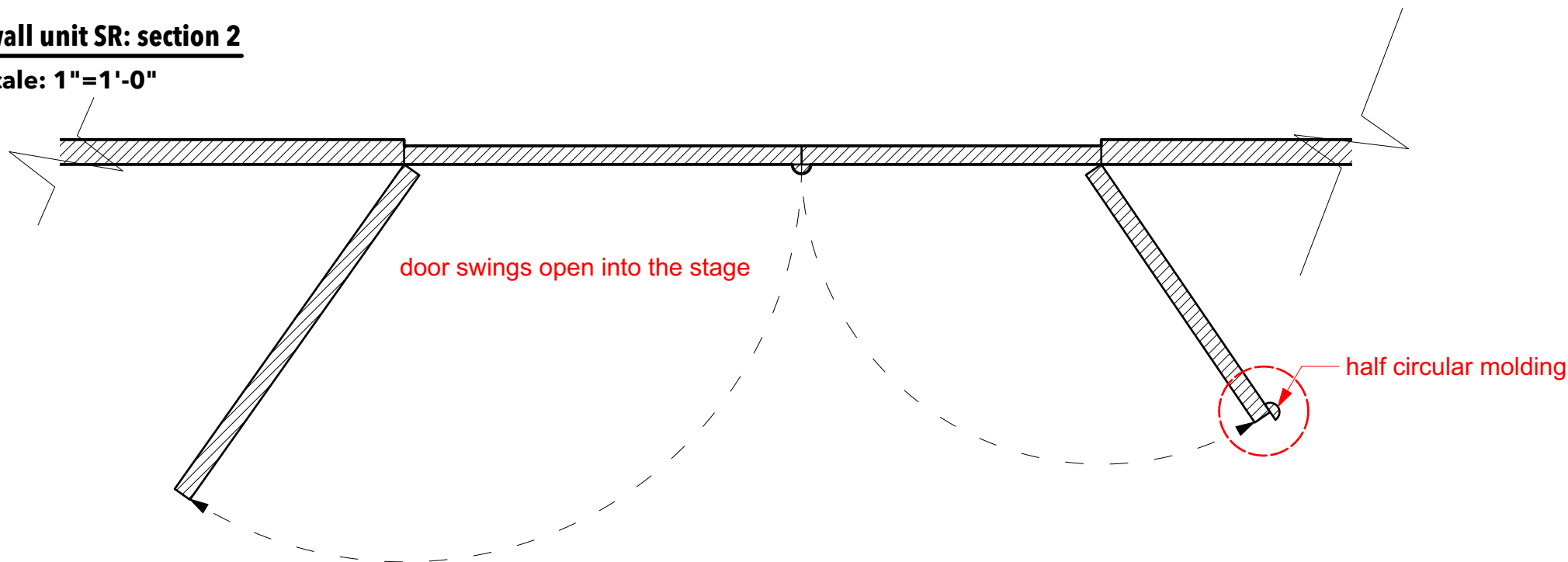

NOTE:

- the crown molding is the only 3 dimensional, the rest of the molding details will be painted.

The Imaginary Invalid
by Moliere

Directing: Alejandro Rodriguez
Costume: Emma Harrison
Lighting: Nick Hogan
Prop: Carrie Tafoy Hess
Tech Directing: Richard Hess
Assistant TD: Alex Houston
Scenic: Inseung Park
Drafting: Inseung Park

The University of New Mexic

Wall unit SR

Scale:

1/2"=1'-0"

Date:

Jan 30, 2024



S.D. 13829
SCENIC DESIGNER
SIGNATURE *[Signature]*

3-1

A-4 wall unit SR ceiling: front

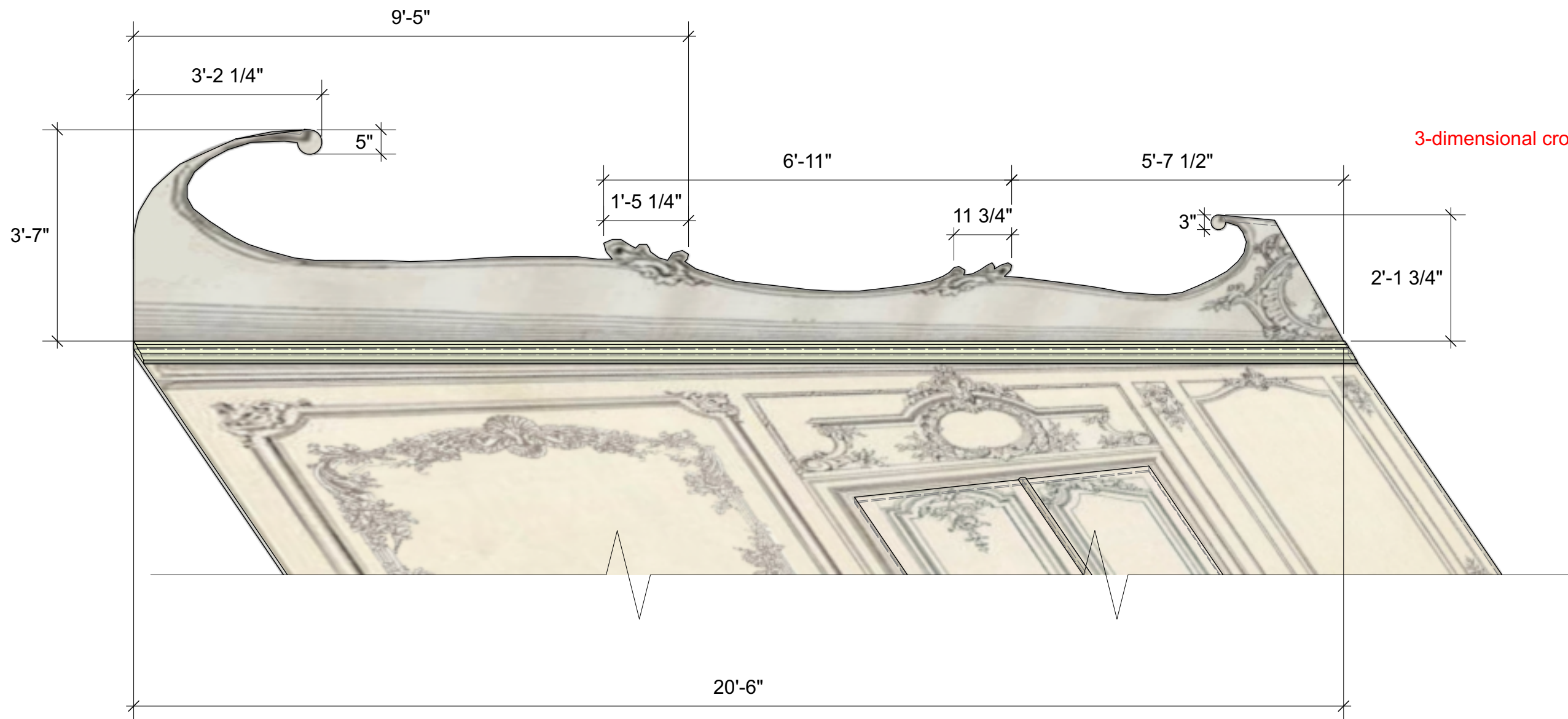

C-1 WC door: front

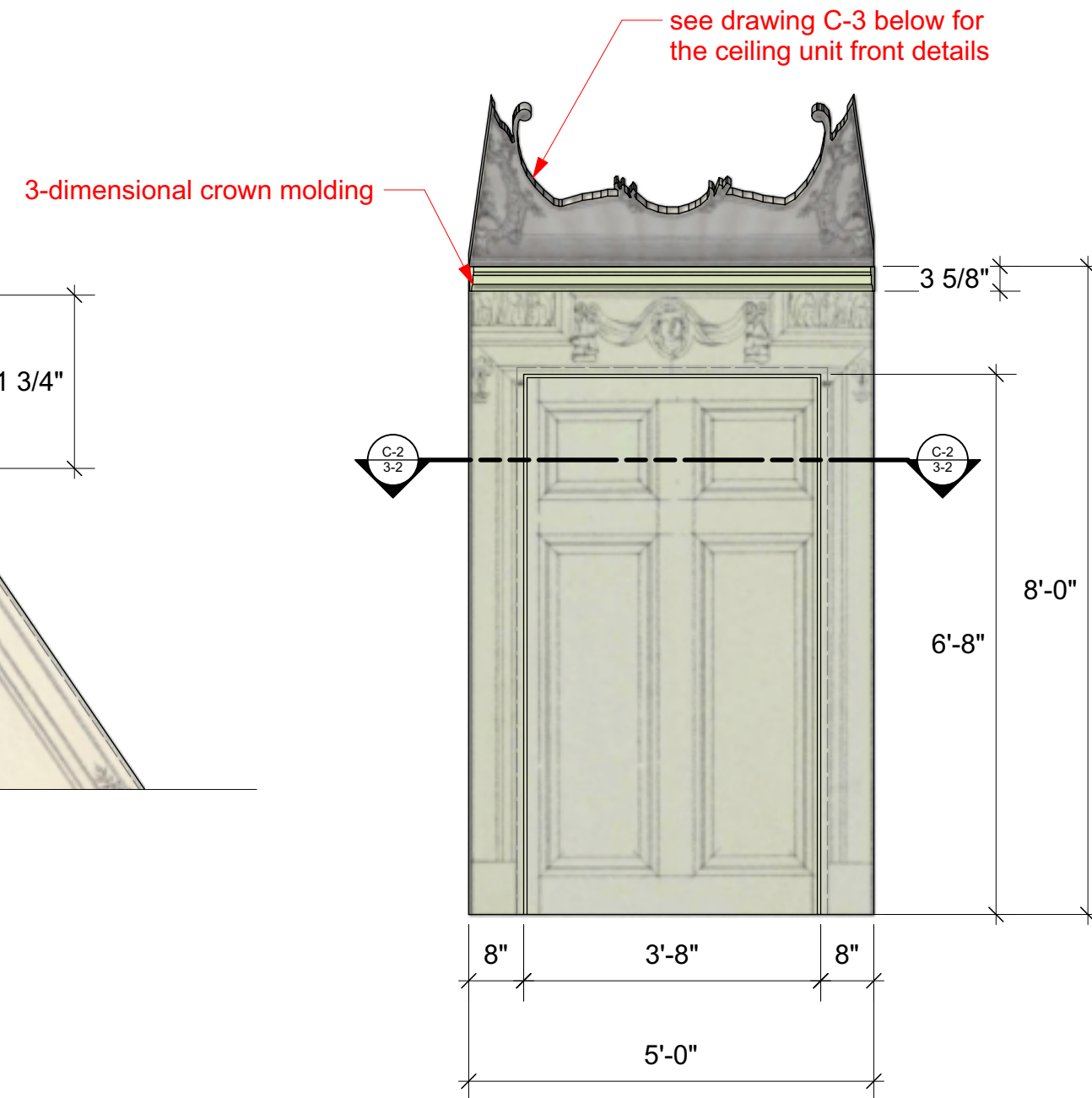

NOTE:

- Need two ceiling moldings for the wall SL and the wall SR - two are mirror images.
- The WC door has the same crown molding as another two walls SL and SR.
- the WC door unit is a symmetry design.

C-3 WC door ceiling unit: front

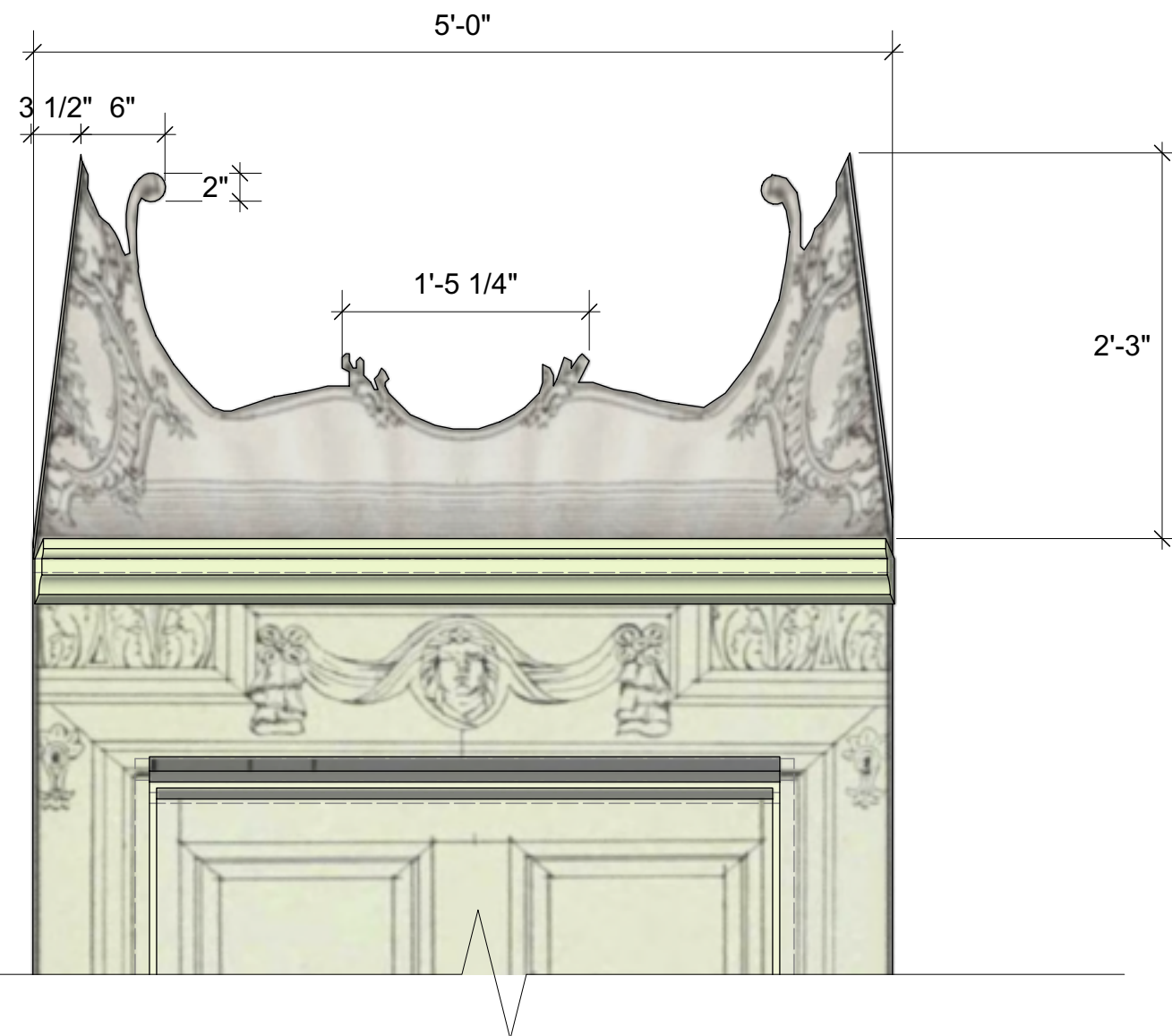

C-2 WC door: section scale: 1"=1'-0"

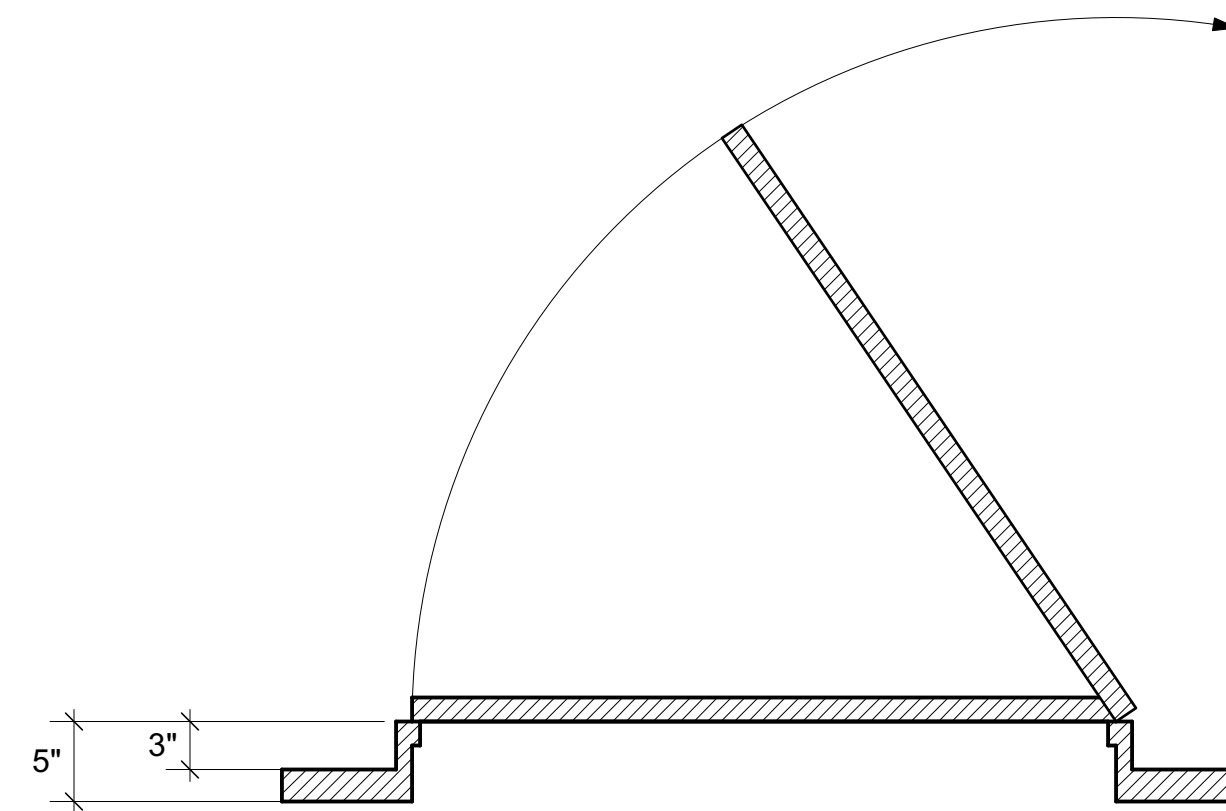

The Imaginary Invalid
by Moliere

Directing: Alejandro Rodriguez
Costume: Emma Harrison
Lighting: Nick Hogan
Prop: Carrie Tafoy Hess
Tech Directing: Richard Hess
Assistant TD: Alex Houston
Scenic: Inseung Park
Drafting: Inseung Park

The University of New Mexic

- Wall unit SR ceiling,
- WC door

Scale:

1/2"=1'-0"

Date:

Jan 30, 2024



S.D. 13829
SCENIC DESIGNER

SIGNATURE *Inseung Park*

B-1 wall unit SL: front

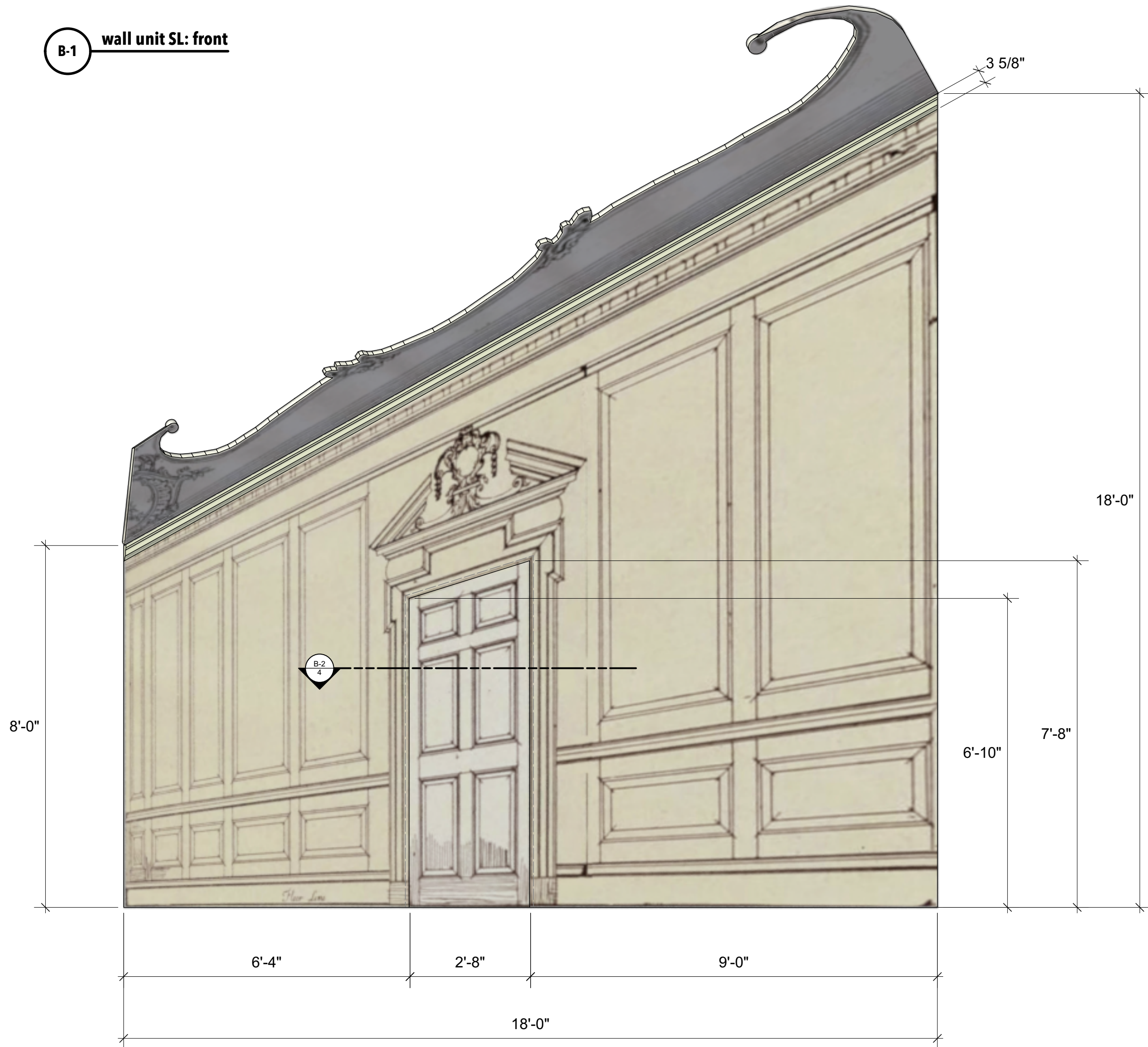

D-1 ceiling rondal: front



B-2 wall unit SL: section
scale: 1"=1'-0"

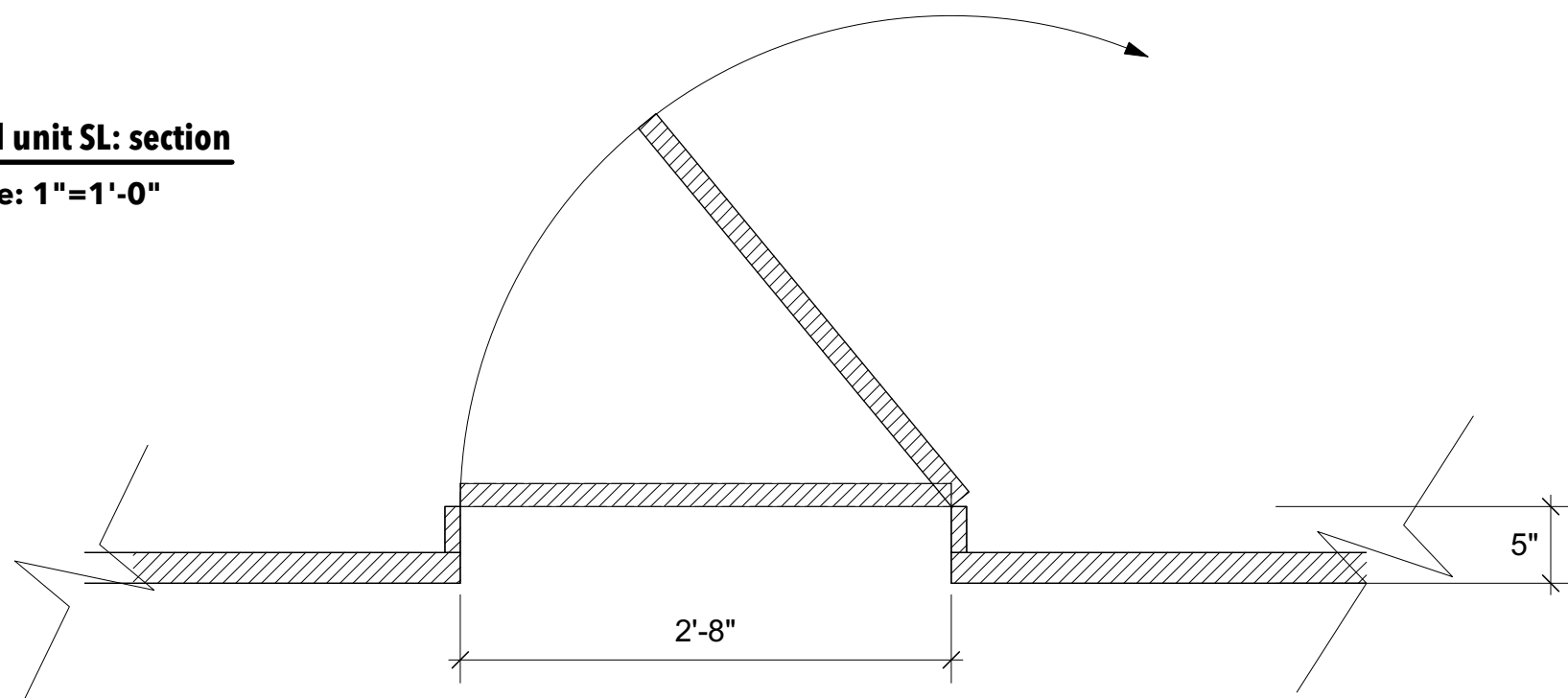

NOTE:

- the wall SL is the same as the wall SR - two are mirror images.
- the doors are different.
- the ceiling units are the same - mirror image.
- the ceiling rondal is a flat oval cut - 8'x7'.

The Imaginary Invalid
by Moliere

Directing: Alejandro Rodriguez
Costume: Emma Harrison
Lighting: Nick Hogan
Prop: Carrie Tafoy Hess
Tech Directing: Richard Hess
Associate TD: Alex Houston
Scenic: Inseung Park
Drafting: Inseung Park

The University of New Mexic

- Wall unit SL
- ceiling rondal

Scale:

1/2"=1'-0"

Date:

Jan 30, 2024



S.D. 13829
SCENIC DESIGNER

SIGNATURE *Inseung Park*